

RECORD CHAINWHEEL SETS WITH BOTTOM
BRACKET SET FOR TRIPLE CHAINRING

pages 72-73-74-75

RECORD CHAINWHEEL SET WITH BOTTOM
BRACKET SET FOR CYCLOCROSS

pages 76-77

RALLY GEAR FOR LARGE RATIOS

page 78

1048/3 CAMPAGNOLO SPECIAL RECORD CHAINWHEEL SET WITH BOTTOM BRACKET SET FOR TRIPLE CHAINRING

- 1046 Record bottom bracket set (with spindle 65-P-110 and cups threaded $\varnothing 36 \times 24F.$). Upon request is furnished the bracket safety sleeve ref. 2110 - 2110/1. See page 81
- 1049/3 Record road chainset for normal triple chainring (with cranks 170 mm., pedal hole $\varnothing 9/16'' \times 20F.$ and chainrings for chain $1/2'' \times 3/32''$ [2 mm.]). Specify the number of teeth of the 3 chainrings available from 42T to 57T. Upon request

1048/3

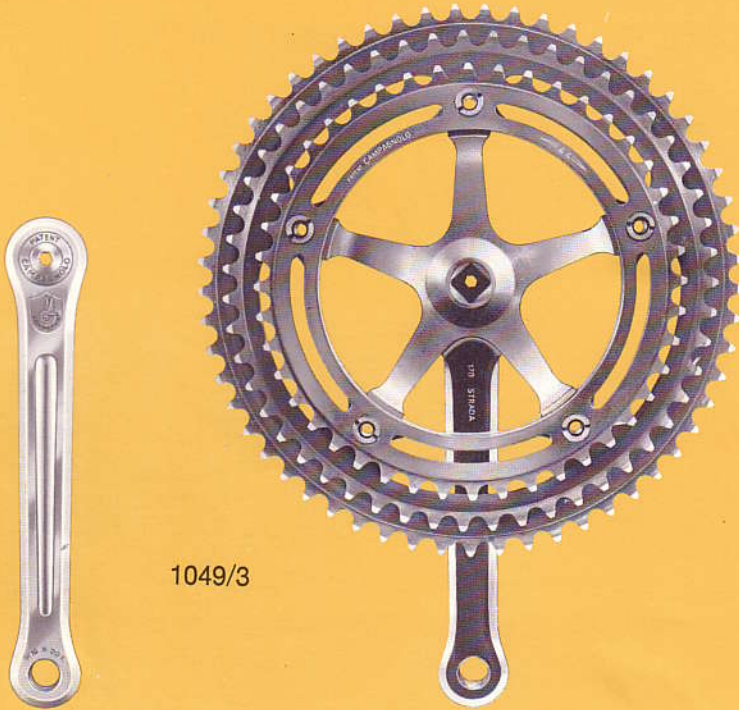

1049/3



1046

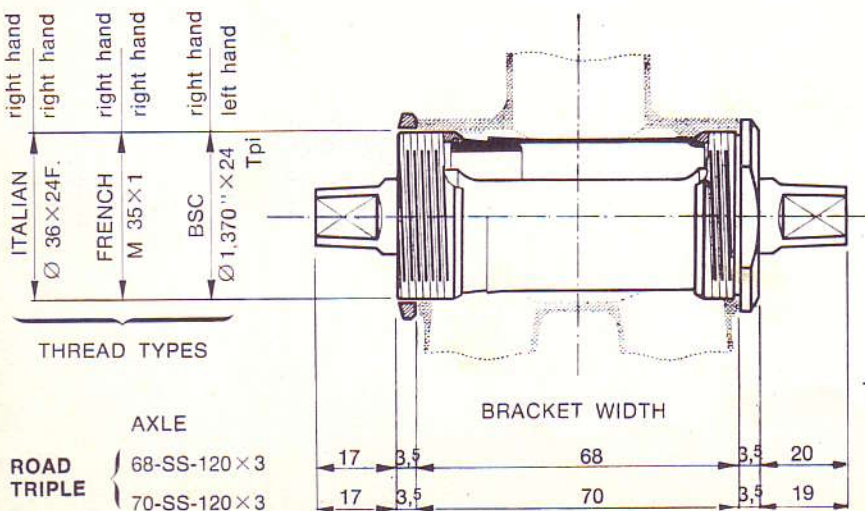

Details of bracket number:

- The first number indicates the bracket width
- P indicates track
- SS indicates road
- C indicates cross
- Number 110 or 120 indicates the suggested width of the rear hub for a perfect chain alignment (see pages 92-93)

UPON REQUEST WE SUPPLY THE CUPS WITH THREAD INCREASED BY 0,5 mm.

744/1 furnished cranks with lengths 165 - 167,5 - 172,5 - 175 - 177,5 and 180 mm.
 Triple chainring cotterless spindle. See measurements and indicate spindle size
 745 Fixed cup.
 Indicate required thread
 746 Adjustable cup.
 Indicate required thread
 747 Lockring with normal 3,5 mm. thickness (available also with 4 mm. and 4,5 mm. thickness)
 Indicate required thread

748 Fixing screw
 749 Fixing washer
 751 Right hand road crank (complete with cover 756, 170 mm. long). Upon request are furnished the following sizes: 165 - 167,5 - 172,5 - 175 - 177,5 and 180 mm. long
 752 Left hand road crank complete with cover 756, 170 mm. long). Upon request are furnished the following sizes: 165 - 167,5 - 172,5 - 175 - 177,5 and 180 mm. long

753 Road chainring for 1/2" x 3/32" (2 mm). chain. Specify the number of teeth available from 42T to 57T
 756 Crank cover plate
 830 Triple chainring and cyclocross fixing bolt
 831 Nut for bolt 830
 832 Triple chainring and cyclocross spacer
 2100 Set (11+11) special \varnothing 1/4" balls selected with 1/1000 of mm. tolerance

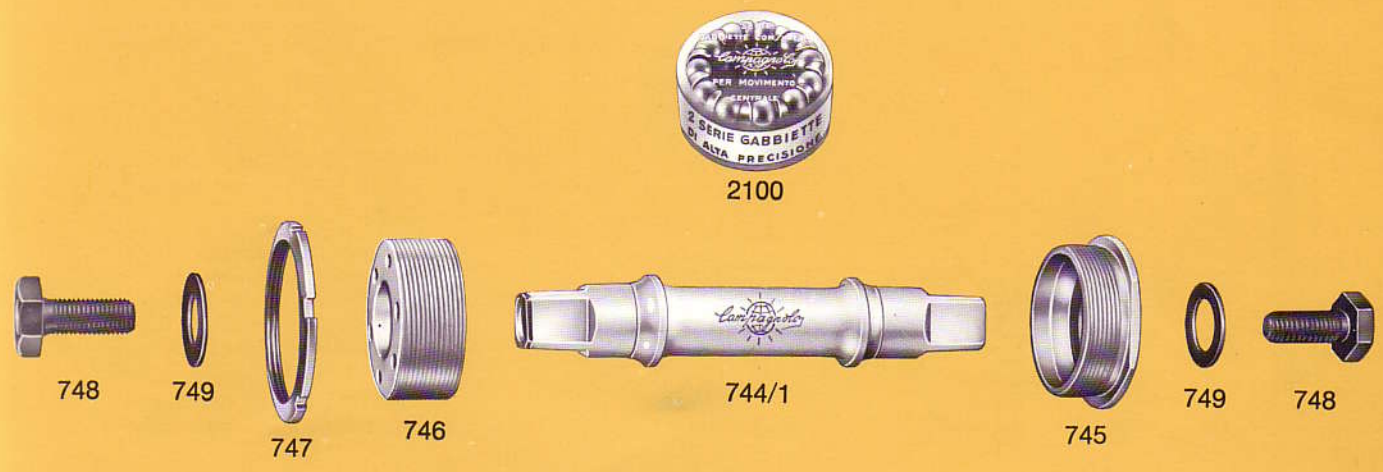
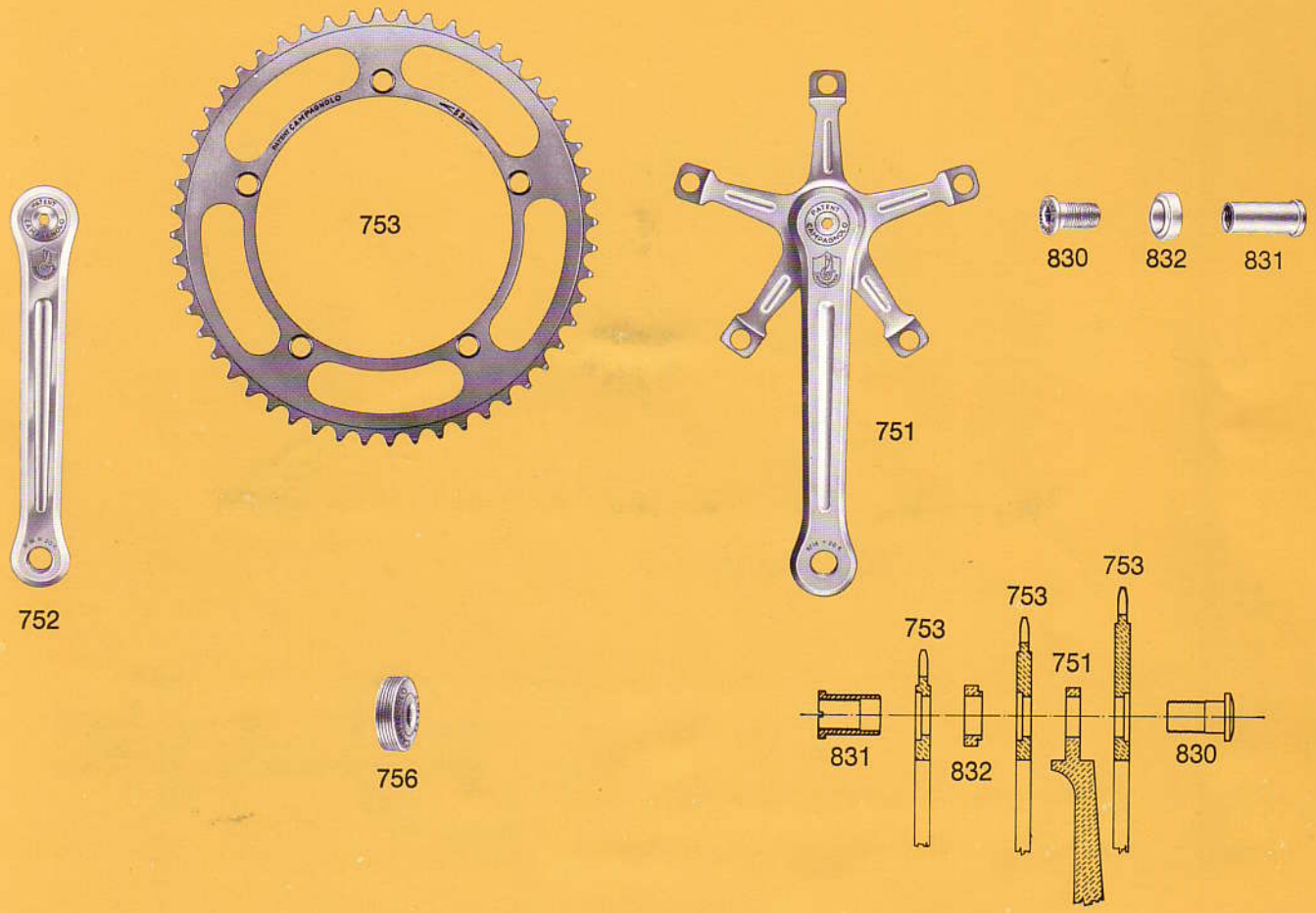

1048/5 CAMPAGNOLO RECORD CHAINWHEEL SET WITH BOTTOM BRACKET SET FOR TRIPLE CHAINRING

- 1046 Record bottom bracket set (with spindle 65-P-110 and cups threaded $\varnothing 36 \times 24F.$). Upon request is furnished the bracket safety sleeve ref. 2110 - 2110/1. See page 81
- 1049/5 Triple Record chainset (with cranks 170 mm., pedal hole $\varnothing 9/16'' \times 20F.$ and chainrings for chain $1/2'' \times 3/32''$ (2 mm). with small ring in 36T only. Specify the number of the other two chainrings available from 42T to 57T

1048/5



1049/5



1046

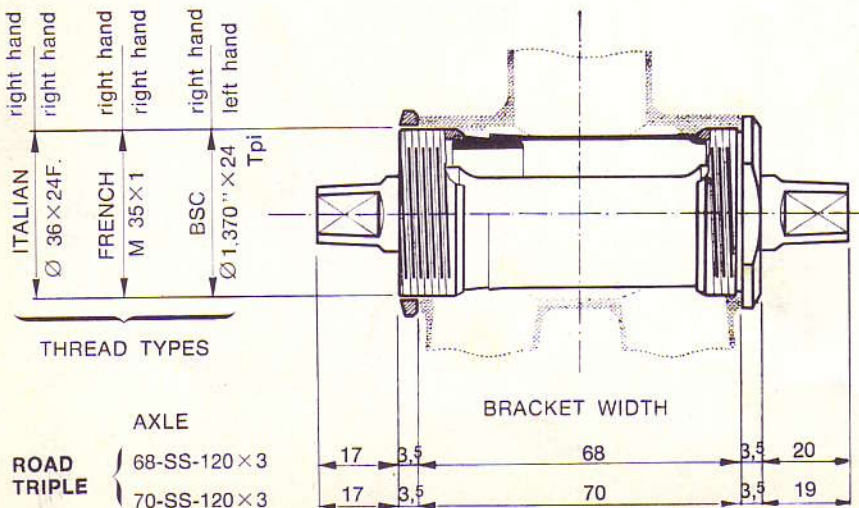

Details of bracket number:

- The first number indicates the bracket width
- P indicates track
- SS indicates road
- C indicates cross
- Number 110 or 120 indicates the suggested width of the rear hub for a perfect chain alignment (see pages 92-93)

UPON REQUEST WE SUPPLY THE CUPS WITH THREAD INCREASED BY 0,5 mm.

- 744/1 Triple chainring cotterless spindle. See measurements and indicate spindle size
- 745 Fixed cup. Indicate required thread
- 746 Adjustable cup. Indicate required thread
- 747 Lockring with normal 3,5 mm. thickness (available also with 4 mm. and 4,5 mm. thickness) Indicate required thread

- 748 Fixing screw
- 749 Fixing washer
- 752 Road left hand crank (complete with cover 756, 170 mm. long)
- 753 Road chainring for 1/2" x 3/32" (2 mm.) chain. Specify the number of teeth available from 42T to 57T
- 754 Road chainwheel fastening screw
- 755 Road chainwheel fastening nut
- 756 Crank cover plate

- 761 Track chainwheel fastening screw
- 804 Chainring for 1/2" x 3/32" (2 mm.) chain with fixed 36 teeth
- 818 Triple chainring spacer
- 819 Right crank for special triple chainring (complete with cover plate 756 - 170 mm. long)
- 2100 Set (11+11) special \varnothing 1/4" balls selected with 1/1000 of mm. tolerance

